

# LM2585 SIMPLE SWITCHER® 3A Flyback Regulator

## General Description

The LM2585 series of regulators are monolithic integrated circuits specifically designed for flyback, step-up (boost), and forward converter applications. The device is available in 4 different output voltage versions: 3.3V, 5.0V, 12V, and adjustable.

Requiring a minimum number of external components, these regulators are cost effective, and simple to use. Included in the datasheet are typical circuits of boost and flyback regulators. Also listed are selector guides for diodes and capacitors and a family of standard inductors and flyback transformers designed to work with these switching regulators.

The power switch is a 3.0A NPN device that can stand-off 65V. Protecting the power switch are current and thermal limiting circuits, and an undervoltage lockout circuit. This IC contains a 100 kHz fixed-frequency internal oscillator that permits the use of small magnetics. Other features include soft start mode to reduce in-rush current during start up, current mode control for improved rejection of input voltage and output load transients and cycle-by-cycle current limiting. An output voltage tolerance of  $\pm 4\%$ , within specified input voltages and output load conditions, is guaranteed for the power supply system.

## Features

- Requires few external components
- Family of standard inductors and transformers
- NPN output switches 3.0A, can stand off 65V
- Wide input voltage range: 4V to 40V
- Current-mode operation for improved transient response, line regulation, and current limit
- 100 kHz switching frequency
- Internal soft-start function reduces in-rush current during start-up
- Output transistor protected by current limit, under voltage lockout, and thermal shutdown
- System Output Voltage Tolerance of  $\pm 4\%$  max over line and load conditions

## Typical Applications

- Flyback regulator
- Multiple-output regulator
- Simple boost regulator
- Forward converter

## Connection Diagrams

**Bent, Staggered Leads  
5-Lead TO-220 (T)  
Top View**



1251514

**Bent, Staggered Leads  
5-Lead TO-220 (T)  
Side View**



1251515

**Order Number LM2585T-3.3, LM2585T-5.0,  
LM2585T-12 or LM2585T-ADJ  
See NS Package Number T05D**

**5-Lead TO-263 (S)  
Top View**

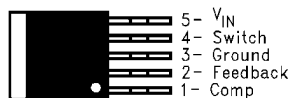

1251516

**Order Number LM2585S-3.3, LM2585S-5.0,  
LM2585S-12 or LM2585S-ADJ**

**5-Lead TO-263 (S)  
Side View**



1251517

**See NS Package Number TS5B**

## Ordering Information

| Package Type                        | NSC Package Drawing | Order Number  |
|-------------------------------------|---------------------|---|
| 5-Lead TO-220 Bent, Staggered Leads | T05D                | LM2585T-3.3, LM2585T-5.0, LM2585T-12, LM2585T-ADJ     |
| 5-Lead TO-263                       | TS5B                | LM2585S-3.3, LM2585S-5.0, LM2585S-12, LM2585S-ADJ     |
| 5-Lead TO-263 Tape and Reel         | TS5B                | LM2585SX-3.3, LM2585SX-5.0, LM2585SX-12, LM2585SX-ADJ |

## Absolute Maximum Ratings (Note 1)

If Military/Aerospace specified devices are required, please contact the National Semiconductor Sales Office/Distributors for availability and specifications.

|  |                                   |
|--|-----------------------------------|
| Input Voltage                            | $-0.4V \leq V_{IN} \leq 45V$      |
| Switch Voltage                           | $-0.4V \leq V_{SW} \leq 65V$      |
| Switch Current (Note 2)                  | Internally Limited                |
| Compensation Pin Voltage                 | $-0.4V \leq V_{COMP} \leq 2.4V$   |
| Feedback Pin Voltage                     | $-0.4V \leq V_{FB} \leq 2V$       |
| Storage Temperature Range                | $-65^{\circ}C$ to $+150^{\circ}C$ |
| Lead Temperature<br>(Soldering, 10 sec.) | 260°C                             |

|  |                    |
|--|--------------------|
| Maximum Junction Temperature<br>(Note 3)       | 150°C              |
| Power Dissipation (Note 3)                     | Internally Limited |
| Minimum ESD Rating<br>(C = 100 pF, R = 1.5 kΩ) | 2 kV               |

## Operating Ratings

|                            |  |
|----------------------------|--|
| Supply Voltage             | $4V \leq V_{IN} \leq 40V$                  |
| Output Switch Voltage      | $0V \leq V_{SW} \leq 60V$                  |
| Output Switch Current      | $I_{SW} \leq 3.0A$                         |
| Junction Temperature Range | $-40^{\circ}C \leq T_J \leq +125^{\circ}C$ |

## Electrical Characteristics

### LM2585-3.3

Specifications with standard type face are for  $T_J = 25^{\circ}C$ , and those in **bold type face** apply over full **Operating Temperature Range**. Unless otherwise specified,  $V_{IN} = 5V$ .

| Symbol   | Parameters                        | Conditions   | Typical | Min                 | Max                 | Units |
|--|-----------------------------------|--|---------|---------------------|---------------------|-------|
| <b>SYSTEM PARAMETERS</b> Test Circuit of Figure 2 (Note 4) |                                   |  |         |                     |                     |       |
| $V_{OUT}$  | Output Voltage                    | $V_{IN} = 4V$ to $12V$<br>$I_{LOAD} = 0.3A$ to $1.2A$            | 3.3     | 3.17/ <b>3.14</b>   | 3.43/ <b>3.46</b>   | V     |
| $\Delta V_{OUT}/\Delta V_{IN}$                             | Line Regulation                   | $V_{IN} = 4V$ to $12V$<br>$I_{LOAD} = 0.3A$                      | 20      |                     | 50/ <b>100</b>      | mV    |
| $\Delta V_{OUT}/\Delta I_{LOAD}$                           | Load Regulation                   | $V_{IN} = 12V$<br>$I_{LOAD} = 0.3A$ to $1.2A$                    | 20      |                     | 50/ <b>100</b>      | mV    |
| $\eta$   | Efficiency                        | $V_{IN} = 5V$ , $I_{LOAD} = 0.3A$                                | 76      |                     |                     | %     |
| <b>UNIQUE DEVICE PARAMETERS</b> (Note 5)                   |                                   |  |         |                     |                     |       |
| $V_{REF}$  | Output Reference Voltage          | Measured at Feedback Pin<br>$V_{COMP} = 1.0V$                    | 3.3     | 3.242/ <b>3.234</b> | 3.358/ <b>3.366</b> | V     |
| $\Delta V_{REF}$   | Reference Voltage Line Regulation | $V_{IN} = 4V$ to $40V$   | 2.0     |                     |                     | mV    |
| $G_M$  | Error Amp Transconductance        | $I_{COMP} = -30 \mu A$ to $+30 \mu A$<br>$V_{COMP} = 1.0V$       | 1.193   | <b>0.678</b>        | <b>2.259</b>        | mmho  |
| $A_{VOL}$  | Error Amp Voltage Gain            | $V_{COMP} = 0.5V$ to $1.6V$<br>$R_{COMP} = 1.0 M\Omega$ (Note 6) | 260     | 151/ <b>75</b>      |                     | V/V   |

### LM2585-5.0

| Symbol   | Parameters               | Conditions  | Typical | Min                 | Max                 | Units |
|--|--------------------------|---|---------|---------------------|---------------------|-------|
| <b>SYSTEM PARAMETERS</b> Test Circuit of Figure 2 (Note 4) |                          |   |         |                     |                     |       |
| $V_{OUT}$  | Output Voltage           | $V_{IN} = 4V$ to $12V$<br>$I_{LOAD} = 0.3A$ to $1.1A$ | 5.0     | 4.80/ <b>4.75</b>   | 5.20/ <b>5.25</b>   | V     |
| $\Delta V_{OUT}/\Delta V_{IN}$                             | Line Regulation          | $V_{IN} = 4V$ to $12V$<br>$I_{LOAD} = 0.3A$           | 20      |                     | 50/ <b>100</b>      | mV    |
| $\Delta V_{OUT}/\Delta I_{LOAD}$                           | Load Regulation          | $V_{IN} = 12V$<br>$I_{LOAD} = 0.3A$ to $1.1A$         | 20      |                     | 50/ <b>100</b>      | mV    |
| $\eta$   | Efficiency               | $V_{IN} = 12V$ , $I_{LOAD} = 0.6A$                    | 80      |                     |                     | %     |
| <b>UNIQUE DEVICE PARAMETERS</b> (Note 5)                   |                          |   |         |                     |                     |       |
| $V_{REF}$  | Output Reference Voltage | Measured at Feedback Pin<br>$V_{COMP} = 1.0V$         | 5.0     | 4.913/ <b>4.900</b> | 5.088/ <b>5.100</b> | V     |

| Symbol           | Parameters                           | Conditions   | Typical | Min          | Max          | Units |
|------------------|--------------------------------------|--|---------|--------------|--------------|-------|
| $\Delta V_{REF}$ | Reference Voltage<br>Line Regulation | $V_{IN} = 4V$ to $40V$   | 3.3     |              |              | mV    |
| $G_M$            | Error Amp<br>Transconductance        | $I_{COMP} = -30 \mu A$ to $+30 \mu A$<br>$V_{COMP} = 1.0V$       | 0.750   | <b>0.447</b> | <b>1.491</b> | mmho  |
| $A_{VOL}$        | Error Amp<br>Voltage Gain            | $V_{COMP} = 0.5V$ to $1.6V$<br>$R_{COMP} = 1.0 M\Omega$ (Note 6) | 165     | <b>99/49</b> |              | V/V   |

## LM2585-12

| Symbol  | Parameters                           | Conditions   | Typical | Min                | Max                | Units |
|---|--------------------------------------|--|---------|--------------------|--------------------|-------|
| <b>SYSTEM PARAMETERS</b> Test Circuit of <i>Figure 3</i> (Note 4) |                                      |  |         |                    |                    |       |
| $V_{OUT}$   | Output Voltage                       | $V_{IN} = 4V$ to $10V$<br>$I_{LOAD} = 0.2A$ to $0.8A$            | 12.0    | <b>11.52/11.40</b> | <b>12.48/12.60</b> | V     |
| $\Delta V_{OUT}/$<br>$\Delta V_{IN}$                              | Line Regulation                      | $V_{IN} = 4V$ to $10V$<br>$I_{LOAD} = 0.2A$                      | 20      |                    | <b>100/200</b>     | mV    |
| $\Delta V_{OUT}/$<br>$\Delta I_{LOAD}$                            | Load Regulation                      | $V_{IN} = 10V$<br>$I_{LOAD} = 0.2A$ to $0.8A$                    | 20      |                    | <b>100/200</b>     | mV    |
| $\eta$  | Efficiency                           | $V_{IN} = 10V$ , $I_{LOAD} = 0.6A$                               | 93      |                    |                    | %     |
| <b>UNIQUE DEVICE PARAMETERS</b> (Note 5)                          |                                      |  |         |                    |                    |       |
| $V_{REF}$   | Output Reference<br>Voltage          | Measured at Feedback Pin<br>$V_{COMP} = 1.0V$                    | 12.0    | <b>11.79/11.76</b> | <b>12.21/12.24</b> | V     |
| $\Delta V_{REF}$  | Reference Voltage<br>Line Regulation | $V_{IN} = 4V$ to $40V$   | 7.8     |                    |                    | mV    |
| $G_M$   | Error Amp<br>Transconductance        | $I_{COMP} = -30 \mu A$ to $+30 \mu A$<br>$V_{COMP} = 1.0V$       | 0.328   | <b>0.186</b>       | <b>0.621</b>       | mmho  |
| $A_{VOL}$   | Error Amp<br>Voltage Gain            | $V_{COMP} = 0.5V$ to $1.6V$<br>$R_{COMP} = 1.0 M\Omega$ (Note 6) | 70      | <b>41/21</b>       |                    | V/V   |

## LM2585-ADJ

| Symbol  | Parameters                           | Conditions   | Typical | Min                | Max                | Units |
|---|--------------------------------------|--|---------|--------------------|--------------------|-------|
| <b>SYSTEM PARAMETERS</b> Test Circuit of <i>Figure 3</i> (Note 4) |                                      |  |         |                    |                    |       |
| $V_{OUT}$   | Output Voltage                       | $V_{IN} = 4V$ to $10V$<br>$I_{LOAD} = 0.2A$ to $0.8A$            | 12.0    | <b>11.52/11.40</b> | <b>12.48/12.60</b> | V     |
| $\Delta V_{OUT}/$<br>$\Delta V_{IN}$                              | Line Regulation                      | $V_{IN} = 4V$ to $10V$<br>$I_{LOAD} = 0.2A$                      | 20      |                    | <b>100/200</b>     | mV    |
| $\Delta V_{OUT}/$<br>$\Delta I_{LOAD}$                            | Load Regulation                      | $V_{IN} = 10V$<br>$I_{LOAD} = 0.2A$ to $0.8A$                    | 20      |                    | <b>100/200</b>     | mV    |
| $\eta$  | Efficiency                           | $V_{IN} = 10V$ , $I_{LOAD} = 0.6A$                               | 93      |                    |                    | %     |
| <b>UNIQUE DEVICE PARAMETERS</b> (Note 5)                          |                                      |  |         |                    |                    |       |
| $V_{REF}$   | Output Reference<br>Voltage          | Measured at Feedback Pin<br>$V_{COMP} = 1.0V$                    | 1.230   | <b>1.208/1.205</b> | <b>1.252/1.255</b> | V     |
| $\Delta V_{REF}$  | Reference Voltage<br>Line Regulation | $V_{IN} = 4V$ to $40V$   | 1.5     |                    |                    | mV    |
| $G_M$   | Error Amp<br>Transconductance        | $I_{COMP} = -30 \mu A$ to $+30 \mu A$<br>$V_{COMP} = 1.0V$       | 3.200   | <b>1.800</b>       | <b>6.000</b>       | mmho  |
| $A_{VOL}$   | Error Amp<br>Voltage Gain            | $V_{COMP} = 0.5V$ to $1.6V$<br>$R_{COMP} = 1.0 M\Omega$ (Note 6) | 670     | <b>400/200</b>     |                    | V/V   |

| Symbol | Parameters                      | Conditions        | Typical | Min | Max     | Units |
|--------|---------------------------------|-------------------|---------|-----|---------|-------|
| $I_B$  | Error Amp<br>Input Bias Current | $V_{COMP} = 1.0V$ | 125     |     | 425/600 | nA    |

## Electrical Characteristics (All Versions)

| Symbol  | Parameters                                      | Conditions   | Typical | Min     | Max       | Units         |
|---|---|--|---------|---------|-----------|---------------|
| <b>COMMON DEVICE PARAMETERS</b> for all versions (Note 5) |   |  |         |         |           |               |
| $I_S$   | Input Supply<br>Current                         | (Switch Off)<br>(Note 8)   | 11      |         | 15.5/16.5 | mA            |
|   |   | $I_{SWITCH} = 1.8A$  | 50      |         | 100/115   | mA            |
| $V_{UV}$  | Input Supply<br>Undervoltage Lockout            | $R_{LOAD} = 100\Omega$   | 3.30    | 3.05    | 3.75      | V             |
| $f_O$   | Oscillator Frequency                            | Measured at Switch Pin<br>$R_{LOAD} = 100\Omega$<br>$V_{COMP} = 1.0V$      | 100     | 85/75   | 115/125   | kHz           |
| $f_{SC}$  | Short-Circuit<br>Frequency                      | Measured at Switch Pin<br>$R_{LOAD} = 100\Omega$<br>$V_{FEEDBACK} = 1.15V$ | 25      |         |           | kHz           |
| $V_{EAO}$   | Error Amplifier<br>Output Swing                 | Upper Limit<br>(Note 7)  | 2.8     | 2.6/2.4 |           | V             |
|   |   | Lower Limit<br>(Note 8)  | 0.25    |         | 0.40/0.55 | V             |
| $I_{EAO}$   | Error Amp<br>Output Current<br>(Source or Sink) | (Note 9)   | 165     | 110/70  | 260/320   | $\mu A$       |
| $I_{SS}$  | Soft Start Current                              | $V_{FEEDBACK} = 0.92V$<br>$V_{COMP} = 1.0V$                                | 11.0    | 8.0/7.0 | 17.0/19.0 | $\mu A$       |
| D   | Maximum Duty<br>Cycle                           | $R_{LOAD} = 100\Omega$<br>(Note 7)   | 98      | 93/90   |           | %             |
| $I_L$   | Switch Leakage<br>Current                       | Switch Off<br>$V_{SWITCH} = 60V$   | 15      |         | 300/600   | $\mu A$       |
| $V_{SUS}$   | Switch Sustaining<br>Voltage                    | $dV/dT = 1.5V/ns$  |         | 65      |           | V             |
| $V_{SAT}$   | Switch Saturation<br>Voltage                    | $I_{SWITCH} = 3.0A$  | 0.45    |         | 0.65/0.9  | V             |
| $I_{CL}$  | NPN Switch<br>Current Limit                     |  | 4.0     | 3.0     | 7.0       | A             |
| $\theta_{JA}$   | Thermal Resistance                              | T Package, Junction to Ambient<br>(Note 10)                                | 65      |         |           | $^{\circ}C/W$ |
| $\theta_{JA}$   |   | T Package, Junction to Ambient<br>(Note 11)                                | 45      |         |           |               |
| $\theta_{JC}$   |   | T Package, Junction to Case  | 2       |         |           |               |
| $\theta_{JA}$   |   | S Package, Junction to Ambient<br>(Note 12)                                | 56      |         |           |               |
| $\theta_{JA}$   |   | S Package, Junction to Ambient<br>(Note 13)                                | 35      |         |           |               |
| $\theta_{JA}$   |   | S Package, Junction to Ambient<br>(Note 14)                                | 26      |         |           |               |
| $\theta_{JC}$   |   | S Package, Junction to Case  | 2       |         |           |               |

**Note 1:** Absolute Maximum Ratings indicate limits beyond which damage to the device may occur. Operating ratings indicate conditions the device is intended to be functional, but device parameter specifications may not be guaranteed under these conditions. For guaranteed specifications and test conditions, see the Electrical Characteristics.

**Note 2:** Note that switch current and output current are not identical in a step-up regulator. Output current cannot be internally limited when the LM2585 is used as a step-up regulator. To prevent damage to the switch, the output current must be externally limited to 3A. However, output current is internally limited when the LM2585 is used as a flyback regulator (see the Application Hints section for more information).

**Note 3:** The junction temperature of the device ( $T_J$ ) is a function of the ambient temperature ( $T_A$ ), the junction-to-ambient thermal resistance ( $\theta_{JA}$ ), and the power dissipation of the device ( $P_D$ ). A thermal shutdown will occur if the temperature exceeds the maximum junction temperature of the device:  $P_D \times \theta_{JA} + T_{A(MAX)} \geq T_{J(MAX)}$ . For a safe thermal design, check that the maximum power dissipated by the device is less than:  $P_D \leq [(T_{J(MAX)} - T_{A(MAX)})/\theta_{JA}]$ . When calculating the maximum allowable power dissipation, derate the maximum junction temperature—this ensures a margin of safety in the thermal design.

**Note 4:** External components such as the diode, inductor, input and output capacitors can affect switching regulator performance. When the LM2585 is used as shown in Figures *Figure 2* and *Figure 3*, system performance will be as specified by the system parameters.

**Note 5:** All room temperature limits are 100% production tested, and all limits at temperature extremes are guaranteed via correlation using standard Statistical Quality Control (SQC) methods.

**Note 6:** A 1.0 M $\Omega$  resistor is connected to the compensation pin (which is the error amplifier output) to ensure accuracy in measuring  $A_{VOL}$ .

**Note 7:** To measure this parameter, the feedback voltage is set to a low value, depending on the output version of the device, to force the error amplifier output high. Adj:  $V_{FB} = 1.05V$ ; 3.3V:  $V_{FB} = 2.81V$ ; 5.0V:  $V_{FB} = 4.25V$ ; 12V:  $V_{FB} = 10.20V$ .

**Note 8:** To measure this parameter, the feedback voltage is set to a high value, depending on the output version of the device, to force the error amplifier output low. Adj:  $V_{FB} = 1.41V$ ; 3.3V:  $V_{FB} = 3.80V$ ; 5.0V:  $V_{FB} = 5.75V$ ; 12V:  $V_{FB} = 13.80V$ .

**Note 9:** To measure the worst-case error amplifier output current, the LM2585 is tested with the feedback voltage set to its low value (specified in **(Note 7)** and at its high value (specified in **(Note 8)**).

**Note 10:** Junction to ambient thermal resistance (no external heat sink) for the 5 lead TO-220 package mounted vertically, with ½ inch leads in a socket, or on a PC board with minimum copper area.

**Note 11:** Junction to ambient thermal resistance (no external heat sink) for the 5 lead TO-220 package mounted vertically, with ½ inch leads soldered to a PC board containing approximately 4 square inches of (1oz.) copper area surrounding the leads.

**Note 12:** Junction to ambient thermal resistance for the 5 lead TO-263 mounted horizontally against a PC board area of 0.136 square inches (the same size as the TO-263 package) of 1 oz. (0.0014 in. thick) copper.

**Note 13:** Junction to ambient thermal resistance for the 5 lead TO-263 mounted horizontally against a PC board area of 0.4896 square inches (3.6 times the area of the TO-263 package) of 1 oz. (0.0014 in. thick) copper.

**Note 14:** Junction to ambient thermal resistance for the 5 lead TO-263 mounted horizontally against a PC board copper area of 1.0064 square inches (7.4 times the area of the TO-263 package) of 1 oz. (0.0014 in. thick) copper. Additional copper area will reduce thermal resistance further. See the thermal model in *Switchers Made Simple* software.

# Typical Performance Characteristics

**Supply Current vs Temperature**

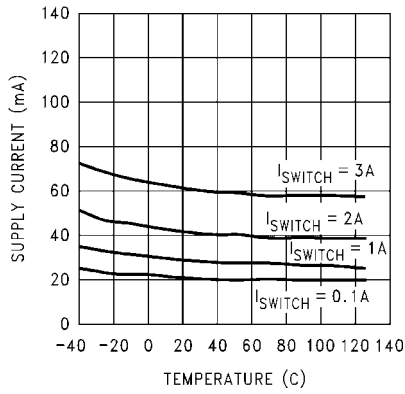

1251502

**Reference Voltage vs Temperature**

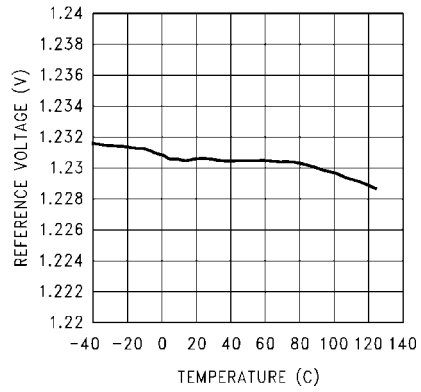

1251503

**ΔReference Voltage vs Supply Voltage**

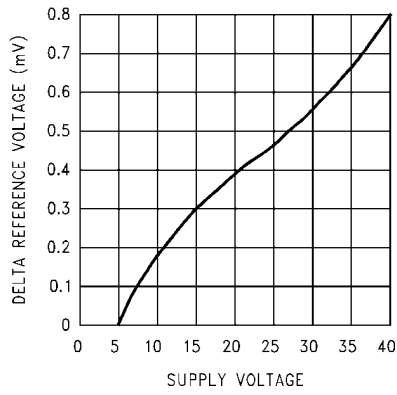

1251504

**Supply Current vs Switch Current**

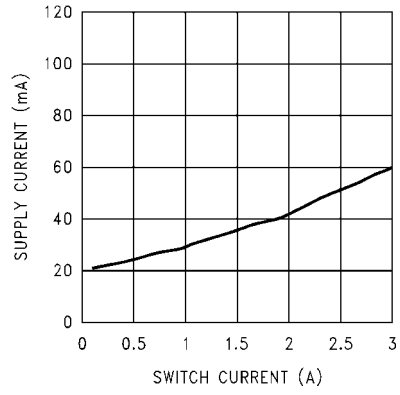

1251505

**Current Limit vs Temperature**

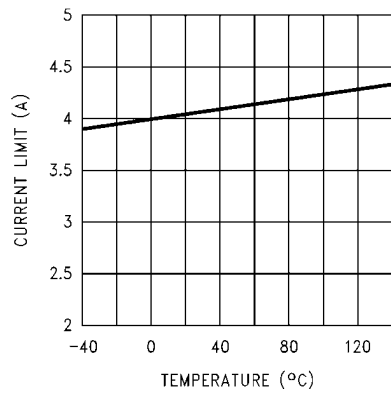

1251506

**Feedback Pin Bias Current vs Temperature**

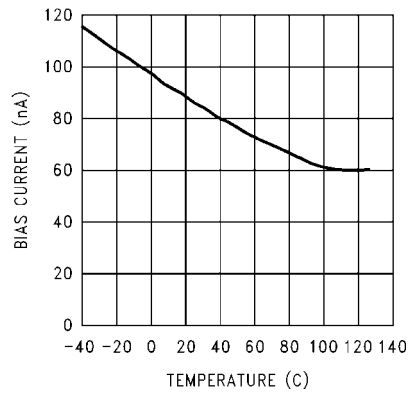

1251507

**Switch Saturation Voltage vs Temperature**

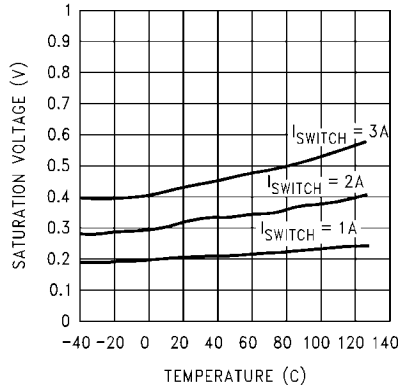

1251508

**Switch Transconductance vs Temperature**

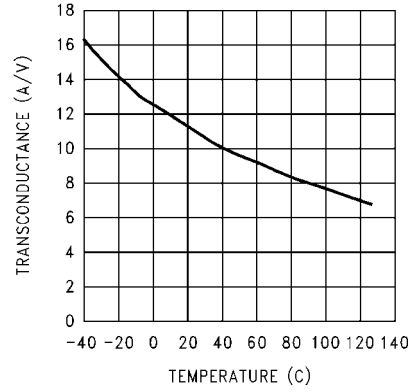

1251509

**Oscillator Frequency vs Temperature**

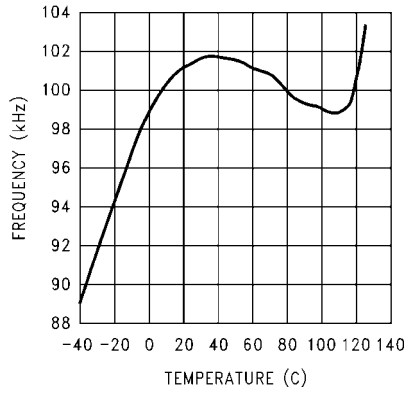

1251510

**Error Amp Transconductance vs Temperature**

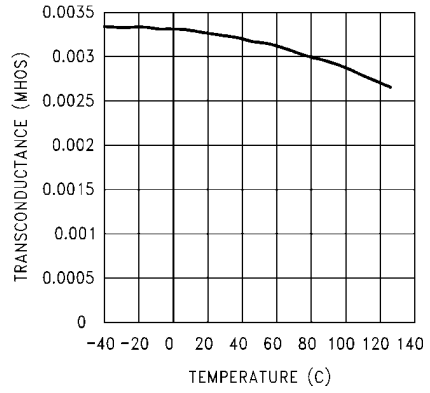

1251511

**Error Amp Voltage Gain vs Temperature**

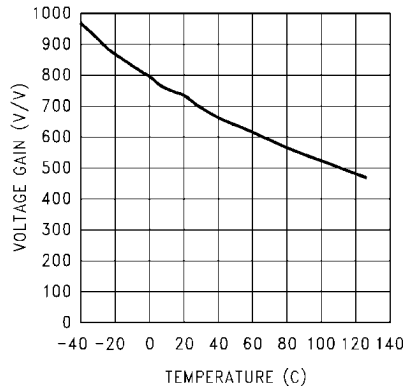

1251512

**Short Circuit Frequency vs Temperature**

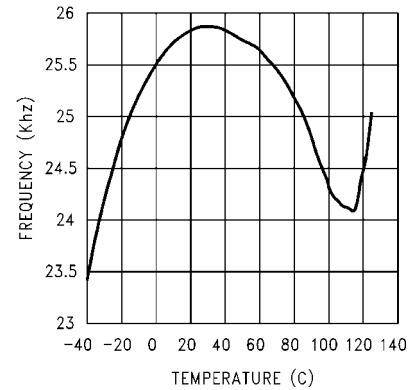

1251513



# Flyback Regulator

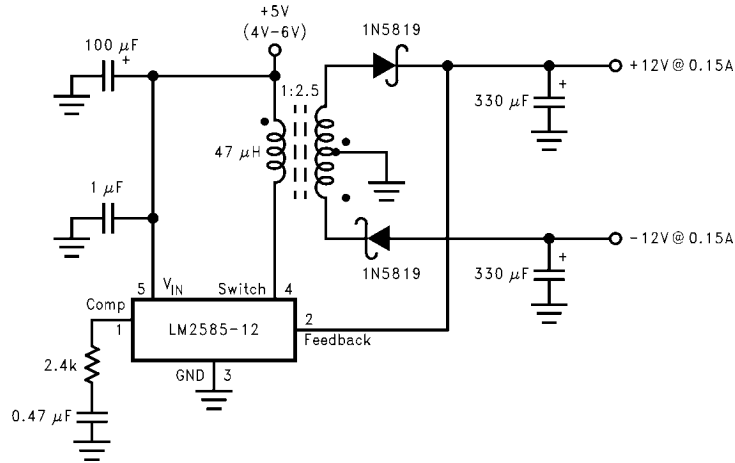

1251501

# Block Diagram

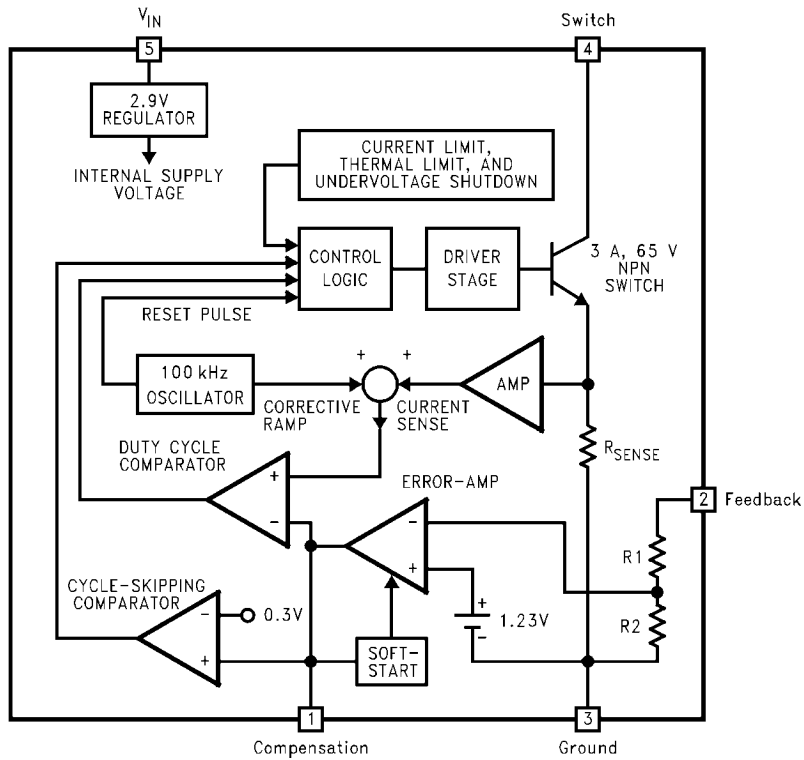

1251518

For Fixed Versions  
 3.3V, R1 = 3.4k, R2 = 2k  
 5V, R1 = 6.15k, R2 = 2k  
 12V, R1 = 8.73k, R2 = 1k  
 For Adj. Version  
 R1 = Short (0Ω), R2 = Open

FIGURE 1.

### Test Circuits

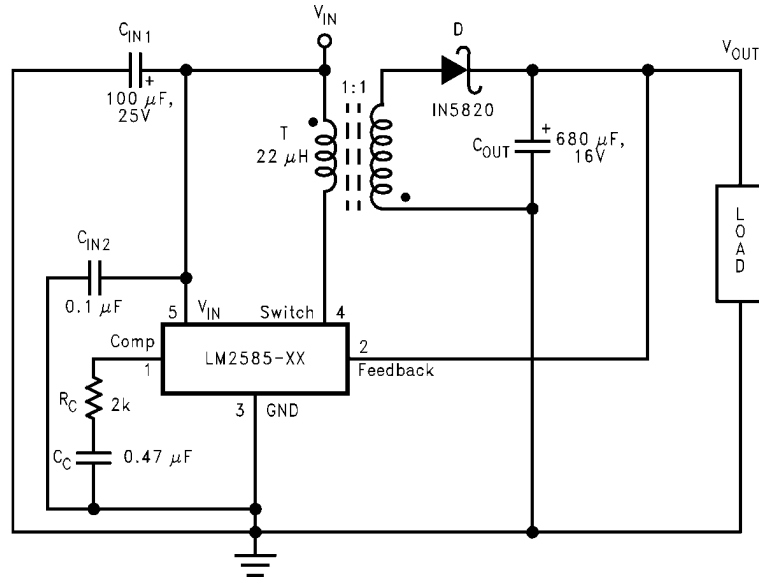

1251519

- C<sub>IN1</sub>—100 μF, 25V Aluminum Electrolytic
- C<sub>IN2</sub>—0.1 μF Ceramic
- T—22 μH, 1:1 Schott #67141450
- D—1N5820
- C<sub>OUT</sub>—680 μF, 16V Aluminum Electrolytic
- C<sub>C</sub>—0.47 μF Ceramic
- R<sub>C</sub>—2k

**FIGURE 2. LM2585-3.3 and LM2585-5.0**

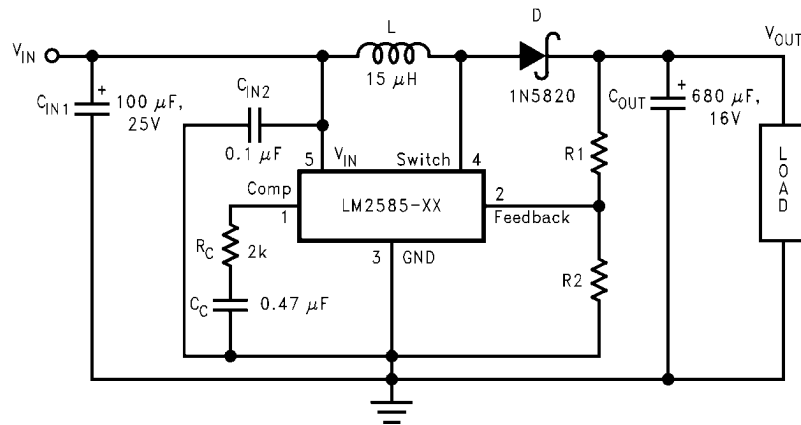

1251520

- C<sub>IN1</sub>—100 μF, 25V Aluminum Electrolytic
- C<sub>IN2</sub>—0.1 μF Ceramic
- L—15 μH, Renco #RL-5472-5
- D—1N5820
- C<sub>OUT</sub>—680 μF, 16V Aluminum Electrolytic
- C<sub>C</sub>—0.47 μF Ceramic
- R<sub>C</sub>—2k
- For 12V Devices: R<sub>1</sub> = Short (0Ω) and R<sub>2</sub> = Open
- For ADJ Devices: R<sub>1</sub> = 48.75k, ±0.1% and R<sub>2</sub> = 5.62k, ±1%

**FIGURE 3. LM2585-12 and LM2585-ADJ**

## Flyback Regulator Operation

The LM2585 is ideally suited for use in the flyback regulator topology. The flyback regulator can produce a single output voltage, such as the one shown in *Figure 4*, or multiple output voltages. In *Figure 4*, the flyback regulator generates an output voltage that is inside the range of the input voltage. This feature is unique to flyback regulators and cannot be duplicated with buck or boost regulators.

The operation of a flyback regulator is as follows (refer to *Figure 4*): when the switch is on, current flows through the primary winding of the transformer, T1, storing energy in the magnetic field of the transformer. Note that the primary and secondary windings are out of phase, so no current flows through the secondary when current flows through the primary.

When the switch turns off, the magnetic field collapses, reversing the voltage polarity of the primary and secondary windings. Now rectifier D1 is forward biased and current flows through it, releasing the energy stored in the transformer. This produces voltage at the output.

The output voltage is controlled by modulating the peak switch current. This is done by feeding back a portion of the output voltage to the error amp, which amplifies the difference between the feedback voltage and a 1.230V reference. The error amp output voltage is compared to a ramp voltage proportional to the switch current (i.e., inductor current during the switch on time). The comparator terminates the switch on time when the two voltages are equal, thereby controlling the peak switch current to maintain a constant output voltage.

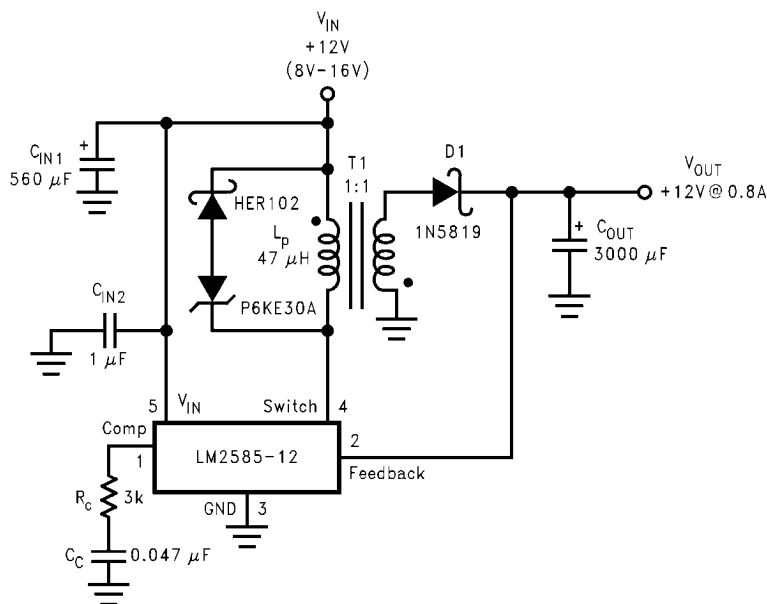

1251521

As shown in *Figure 4*, the LM2585 can be used as a flyback regulator by using a minimum number of external components. The switching waveforms of this regulator are shown in *Figure 5*. Typical Performance Characteristics observed during the operation of this circuit are shown in *Figure 6*.

**FIGURE 4. 12V Flyback Regulator Design Example**

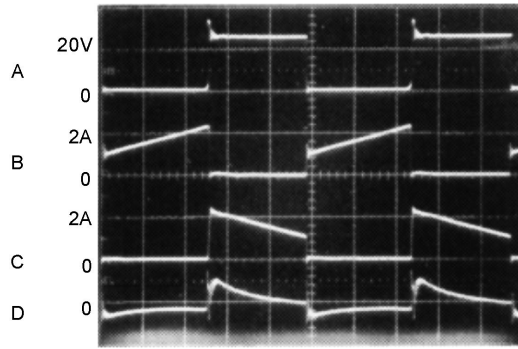

1251522

A: Switch Voltage, 20 V/div  
 B: Switch Current, 2 A/div  
 C: Output Rectifier Current, 2 A/div  
 D: Output Ripple Voltage, 50 mV/div  
 AC-Coupled  
 Horizontal: 2  $\mu$ s/div

**FIGURE 5. Switching Waveforms**

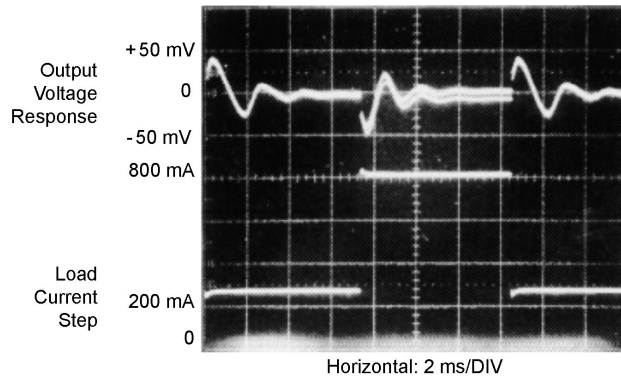

1251523

**FIGURE 6.  $V_{OUT}$  Load Current Step Response**

## Typical Flyback Regulator Applications

Figure 7 through Figure 12 show six typical flyback applications, varying from single output to triple output. Each drawing contains the part number(s) and manufacturer(s) for every

component except the transformer. For the transformer part numbers and manufacturers names, see the table in Figure 13. For applications with different output voltages—requiring the LM2585-ADJ—or different output configurations that do not match the standard configurations, refer to the **Switchers Made Simple®** software.

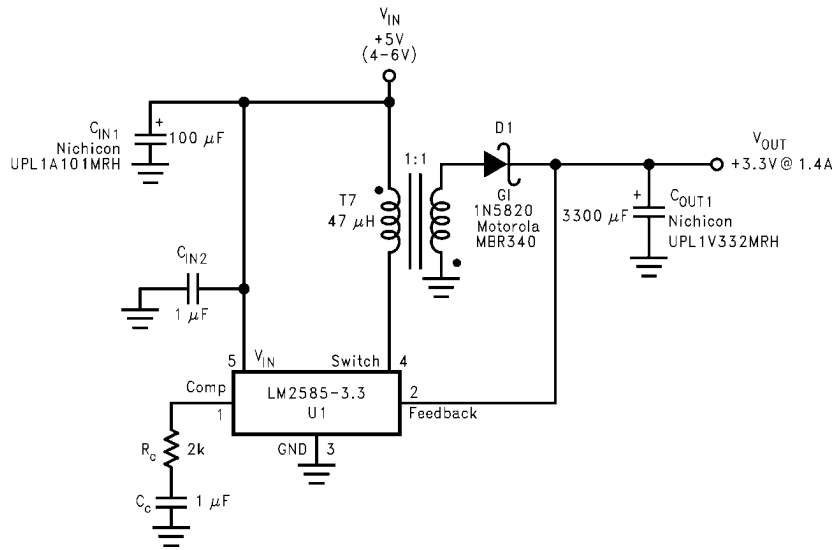

1251524

FIGURE 7. Single-Output Flyback Regulator

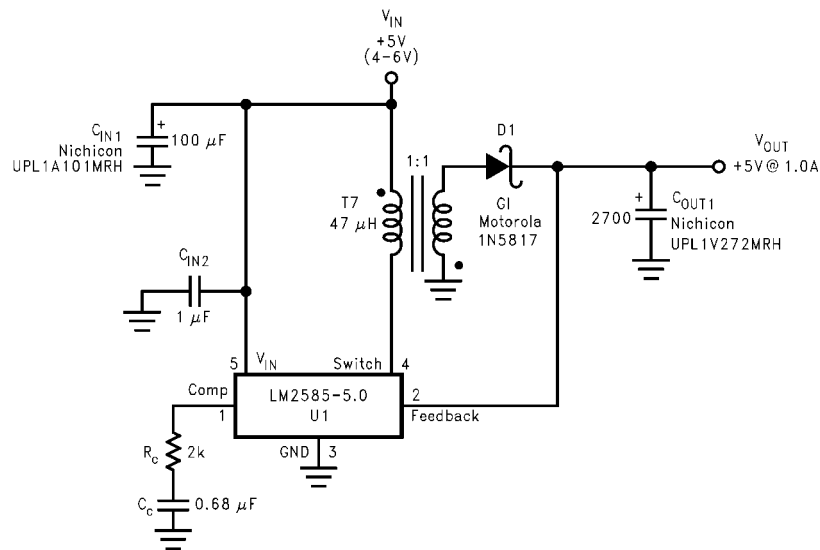

1251525

FIGURE 8. Single-Output Flyback Regulator

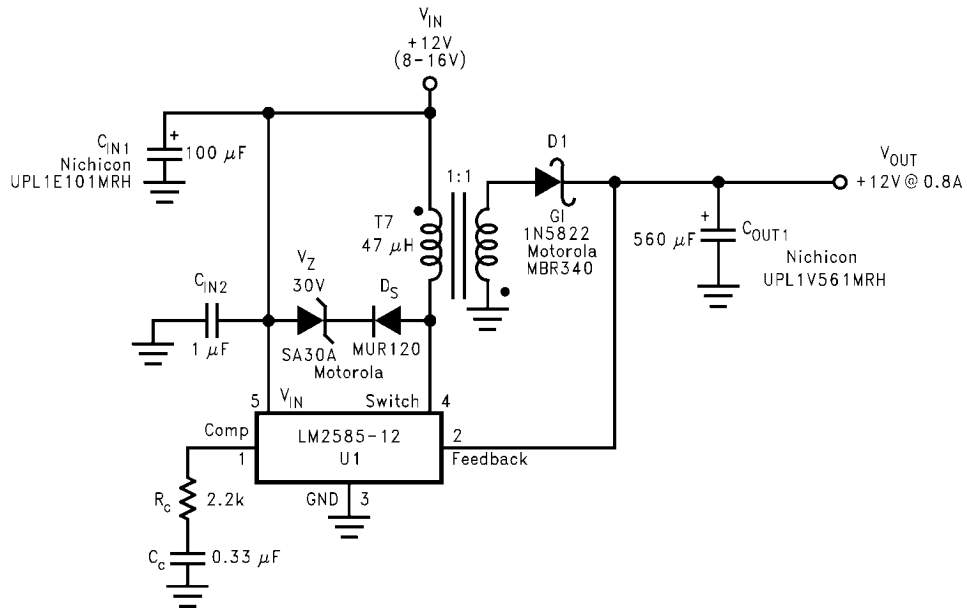

1251526

FIGURE 9. Single-Output Flyback Regulator

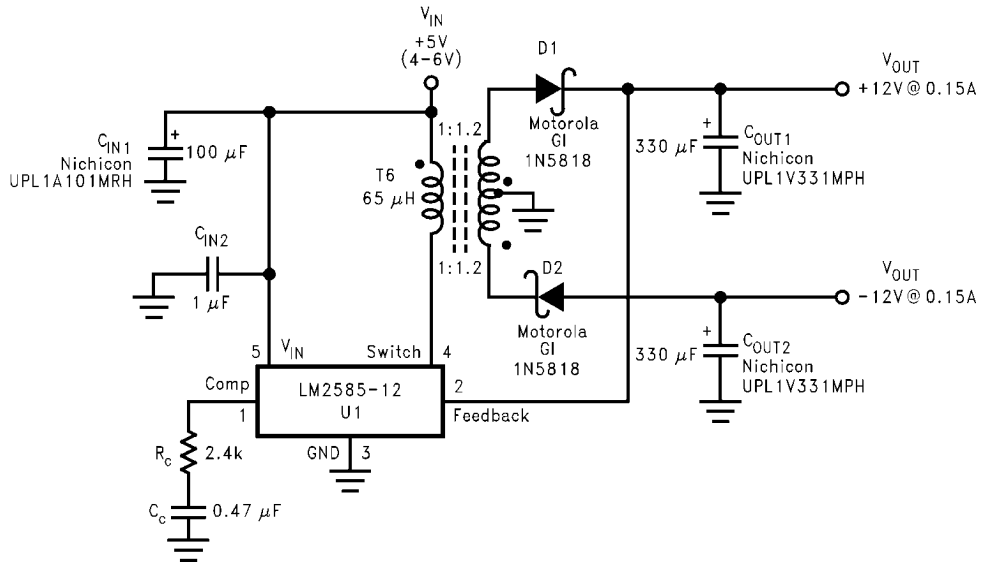

1251527

FIGURE 10. Dual-Output Flyback Regulator

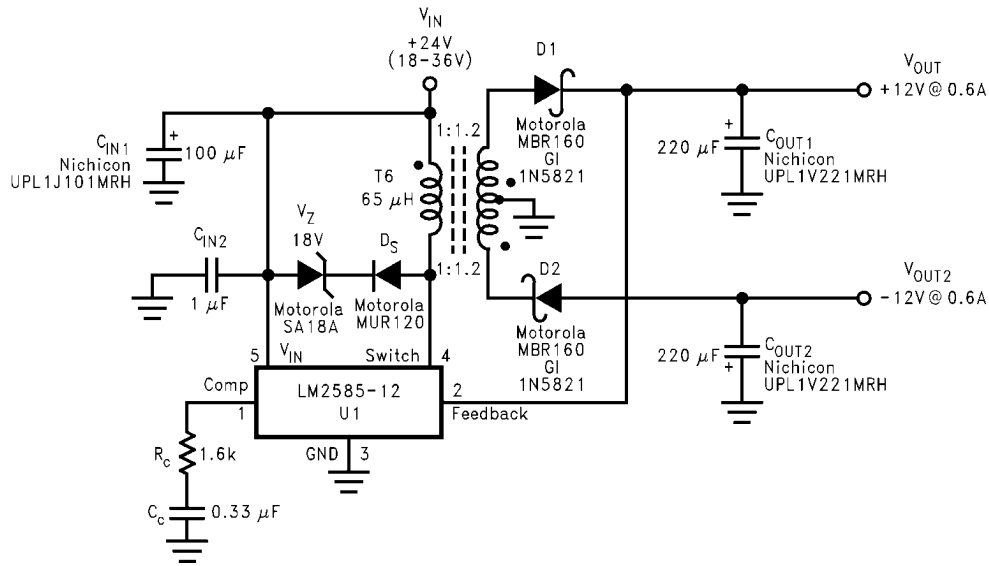

1251528

FIGURE 11. Dual-Output Flyback Regulator

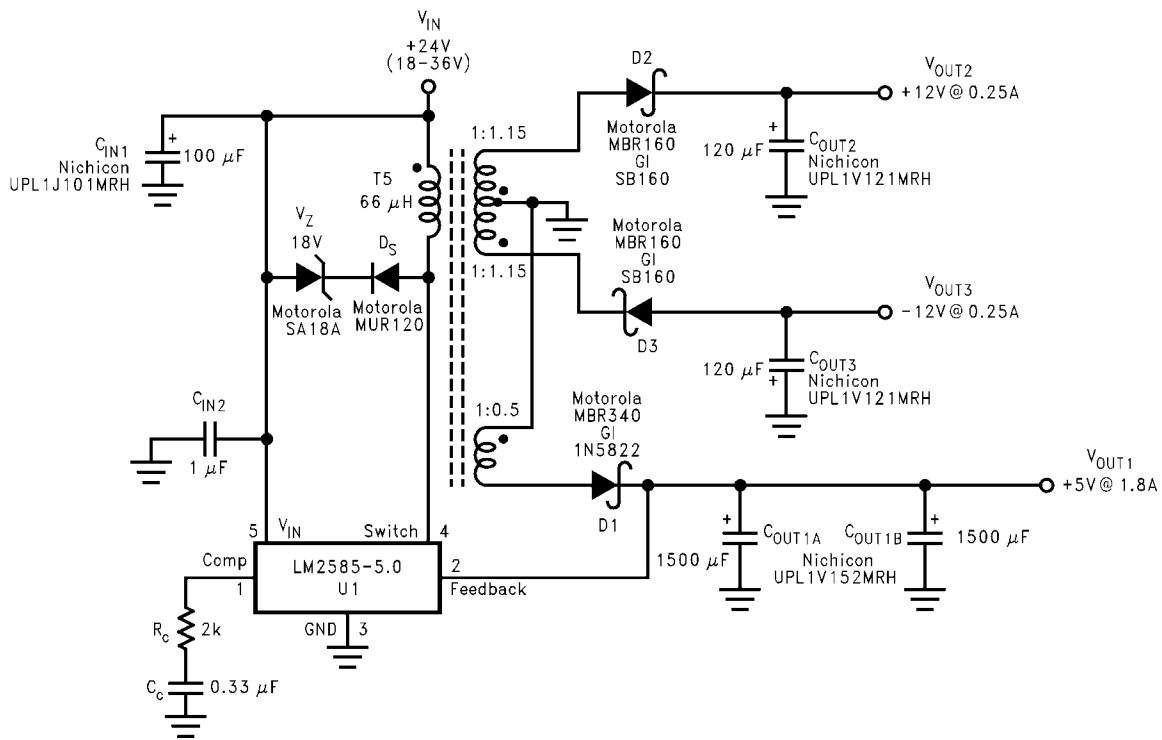

1251529

FIGURE 12. Triple-Output Flyback Regulator

**TRANSFORMER SELECTION (T)**

Figure 13 lists the standard transformers available for flyback regulator applications. Included in the table are the turns ratio

(s) for each transformer, as well as the output voltages, input voltage ranges, and the maximum load currents for each circuit.

| Applications        | Figure 7  | Figure 8  | Figure 9  | Figure 10 | Figure 11 | Figure 12 |
|---------------------|-----------|-----------|-----------|-----------|-----------|-----------|
| <b>Transformers</b> | <b>T7</b> | <b>T7</b> | <b>T7</b> | <b>T6</b> | <b>T6</b> | <b>T5</b> |
| $V_{IN}$            | 4V–6V     | 4V–6V     | 8V–16V    | 4V–6V     | 18V–36V   | 18V–36V   |
| $V_{OUT1}$          | 3.3V      | 5V        | 12V       | 12V       | 12V       | 5V        |
| $I_{OUT1} (Max)$    | 1.4A      | 1A        | 0.8A      | 0.15A     | 0.6A      | 1.8A      |
| $N_1$               | 1         | 1         | 1         | 1.2       | 1.2       | 0.5       |
| $V_{OUT2}$          |           |           |           | –12V      | –12V      | 12V       |
| $I_{OUT2} (Max)$    |           |           |           | 0.15A     | 0.6A      | 0.25A     |
| $N_2$               |           |           |           | 1.2       | 1.2       | 1.15      |
| $V_{OUT3}$          |           |           |           |           |           | –12V      |
| $I_{OUT3} (Max)$    |           |           |           |           |           | 0.25A     |
| $N_3$               |           |           |           |           |           | 1.15      |

**FIGURE 13. Transformer Selection Table**

| Transformer Type | Manufacturers' Part Numbers |   |                                     |                    |                    |                     |
|------------------|-----------------------------|---|-------------------------------------|--------------------|--------------------|---------------------|
|                  | Coilcraft<br>(Note 15)      | Coilcraft<br>(Note 15)<br>Surface Mount | Pulse<br>(Note 16)<br>Surface Mount | Pulse<br>(Note 16) | Renco<br>(Note 17) | Schott<br>(Note 18) |
| T5               | Q4338-B                     | Q4437-B                                 | PE-68413                            | —                  | RL-5532            | 67140890            |
| T6               | Q4339-B                     | Q4438-B                                 | PE-68414                            | —                  | RL-5533            | 67140900            |
| T7               | S6000-A                     | S6057-A                                 | —                                   | PE-68482           | RL-5751            | 26606               |

**Note 15:** Coilcraft Inc. Phone: (800) 322-2645

1102 Silver Lake Road, Cary, IL 60013: Fax: (708) 639-1469

**Note 16:** Pulse Engineering Inc. Phone: (619) 674-8100

12220 World Trade Drive, San Diego, CA 92128: Fax: (619) 674-8262

**Note 17:** Renco Electronics Inc. Phone: (800) 645-5828

60 Jeffryn Blvd. East, Deer Park, NY 11729: Fax: (516) 586-5562

**Note 18:** Schott Corp. Phone: (612) 475-1173

1000 Parkers Lane Road, Wayzata, MN 55391: Fax: (612) 475-1786

**FIGURE 14. Transformer Manufacturer Guide**



**TRANSFORMER FOOTPRINTS**

Figure 15 through Figure 29 show the footprints of each transformer, listed in Figure 14.

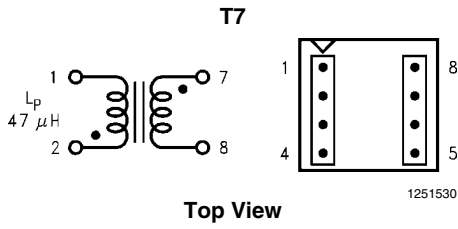

**FIGURE 15. Coilcraft S6000-A**

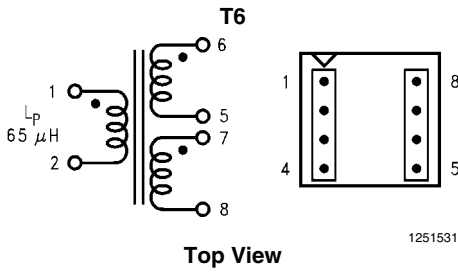

**FIGURE 16. Coilcraft Q4339-B**

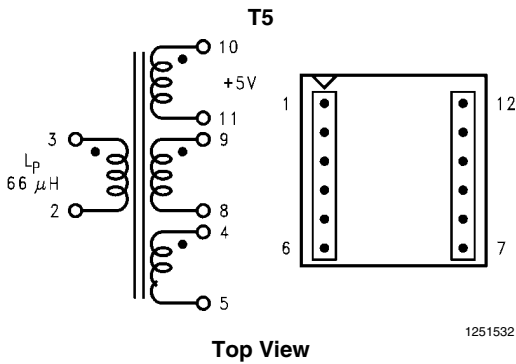

**FIGURE 17. Coilcraft Q4437-B (Surface Mount)**

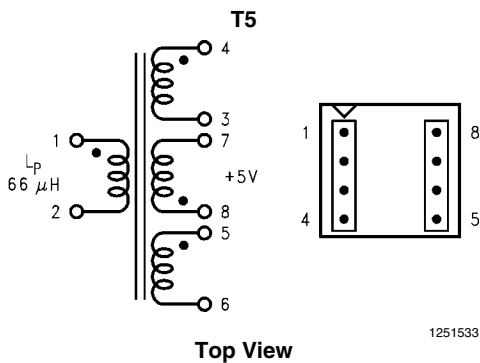

**FIGURE 18. Coilcraft Q4338-B**

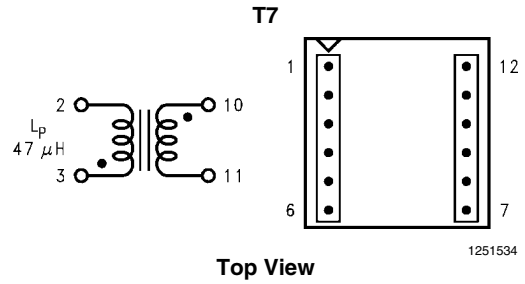

**FIGURE 19. Coilcraft S6057-A (Surface Mount)**

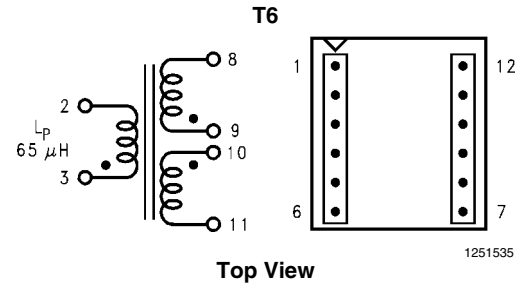

**FIGURE 20. Coilcraft Q4438-B (Surface Mount)**

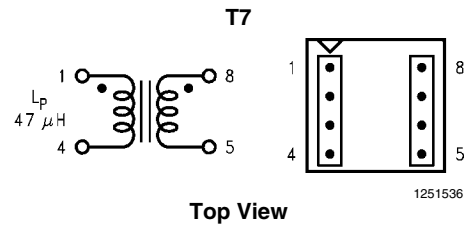

**FIGURE 21. Pulse PE-68482**

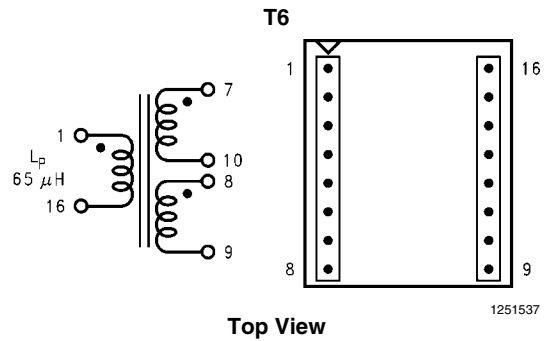

**FIGURE 22. Pulse PE-68414 (Surface Mount)**

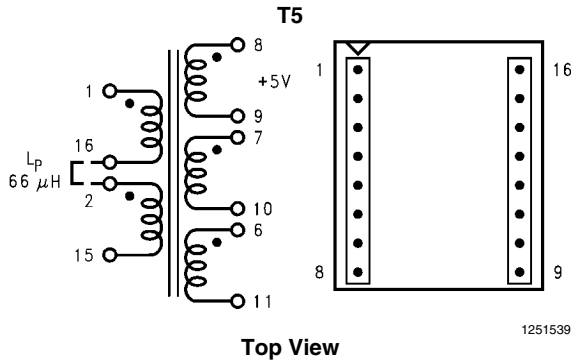

FIGURE 23. Pulse PE-68413 (Surface Mount)

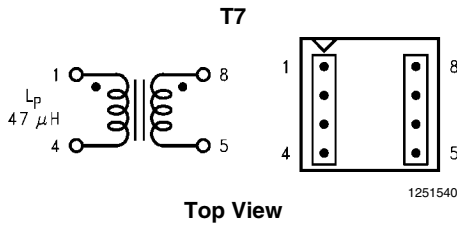

FIGURE 24. Renco RL-5751

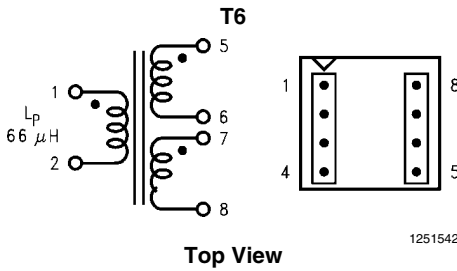

FIGURE 25. Renco RL-5533

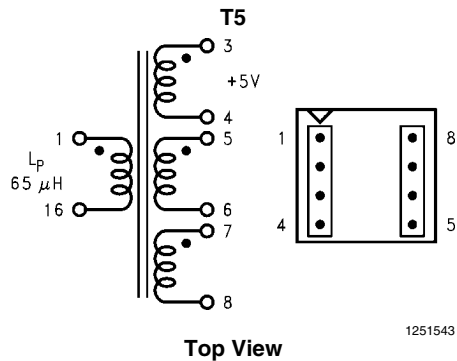

FIGURE 26. Renco RL-5532

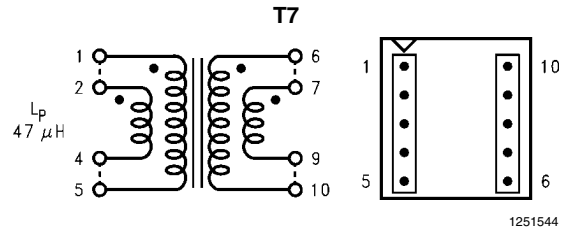

FIGURE 27. Top View Schott 26606

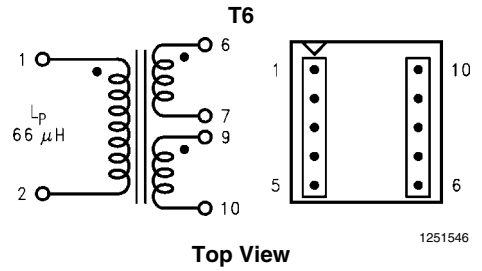

FIGURE 28. Schott 67140900

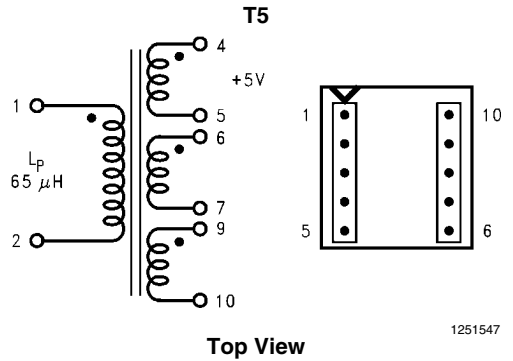
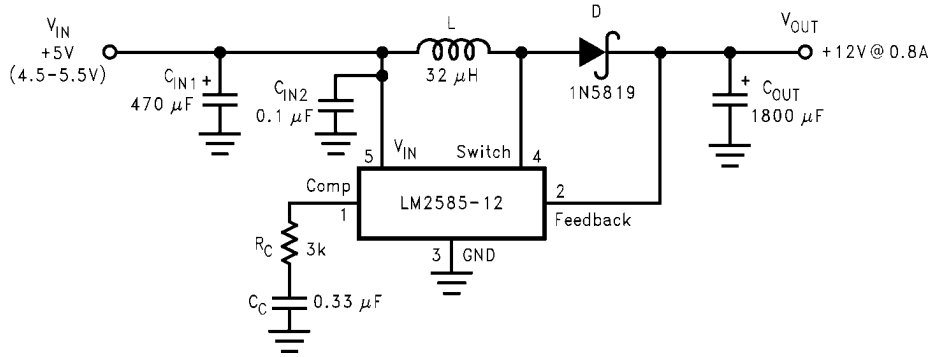

FIGURE 29. Schott 67140890

## Step-Up (Boost) Regulator Operation

Figure 30 shows the LM2585 used as a step-up (boost) regulator. This is a switching regulator that produces an output voltage greater than the input supply voltage.

A brief explanation of how the LM2585 Boost Regulator works is as follows (refer to Figure 30). When the NPN switch turns on, the inductor current ramps up at the rate of  $V_{IN}/L$ , storing energy in the inductor. When the switch turns off, the lower end of the inductor flies above  $V_{IN}$ , discharging its current through diode (D) into the output capacitor ( $C_{OUT}$ ) at a rate of  $(V_{OUT} - V_{IN})/L$ . Thus, energy stored in the inductor during the switch on time is transferred to the output during the switch off time. The output voltage is controlled by adjusting the peak switch current, as described in the flyback regulator section.



1251548

By adding a small number of external components (as shown in *Figure 30*), the LM2585 can be used to produce a regulated output voltage that is greater than the applied input voltage. The switching waveforms observed during the operation of this circuit are shown in *Figure 31*. Typical performance of this regulator is shown in *Figure 32*.

**FIGURE 30. 12V Boost Regulator**

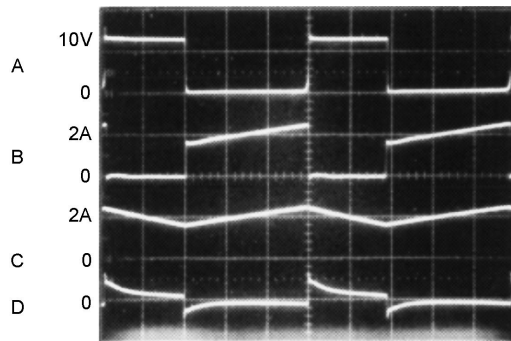

1251549

A: Switch Voltage, 10 V/div  
 B: Switch Current, 2 A/div  
 C: Inductor Current, 2 A/div  
 D: Output Ripple Voltage, 100 mV/div, AC-Coupled  
**Horizontal: 2 μs/div**

**FIGURE 31. Switching Waveforms**

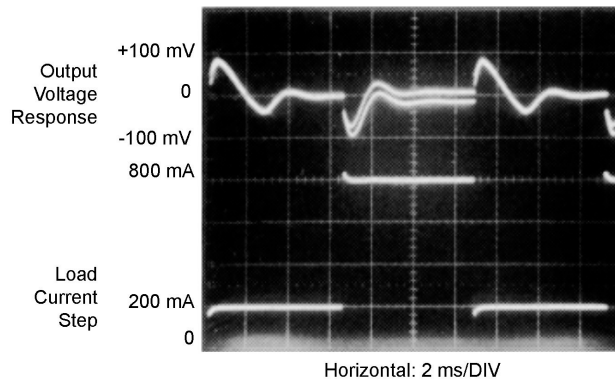

1251550

**FIGURE 32.  $V_{OUT}$  Response to Load Current Step**

# Typical Boost Regulator Applications

Figure 33 and Figure 35 through Figure 37 show four typical boost applications—one fixed and three using the adjustable version of the LM2585. Each drawing contains the part num-

ber(s) and manufacturer(s) for every component. For the fixed 12V output application, the part numbers and manufacturers' names for the inductor are listed in a table in Figure 34. For applications with different output voltages, refer to the **Switchers Made Simple** software.

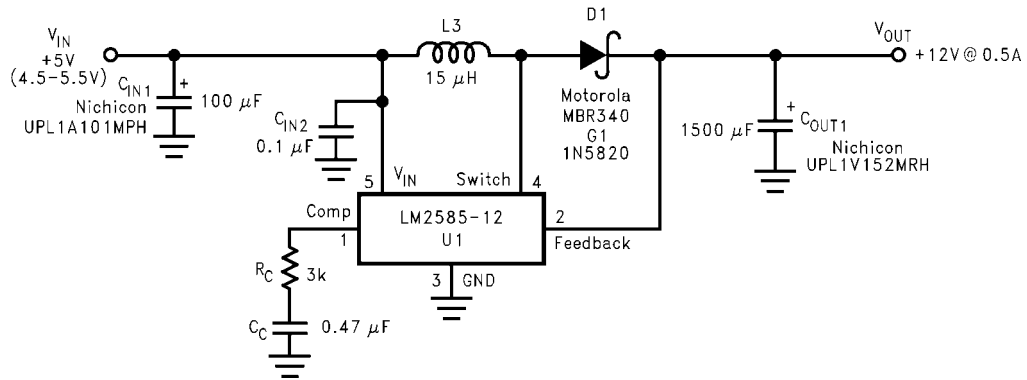

1251551

FIGURE 33. +5V to +12V Boost Regulator

Figure 34 contains a table of standard inductors, by part number and corresponding manufacturer, for the fixed output regulator of Figure 33.

| Coilcraft<br>(Note 19) | Pulse<br>(Note 20) | Renco<br>(Note 21) | Schott<br>(Note 22) | Schott (Note 22)<br>(Surface Mount) |
|------------------------|--------------------|--------------------|---------------------|-------------------------------------|
| D03316-153             | PE-53898           | RL-5471-7          | 67146510            | 67146540                            |

- Note 19:** Coilcraft Inc. Phone: (800) 322-2645  
1102 Silver Lake Road, Cary, IL 60013 Fax: (708) 639-1469
- Note 20:** Pulse Engineering Inc. Phone: (619) 674-8100  
12220 World Trade Drive, San Diego, CA 92128 Fax: (619) 674-8262
- Note 21:** Renco Electronics Inc. Phone (800) 645-5828  
60 Jeffryn Blvd. East, Deer Park, NY 11729 Fax: (516) 586-5562
- Note 22:** Schott Corp. Phone: (612) 475-1173  
1000 Parkers Lane Road, Wayzata, MN 55391 Fax: (612) 475-1786

FIGURE 34. Inductor Selection Table

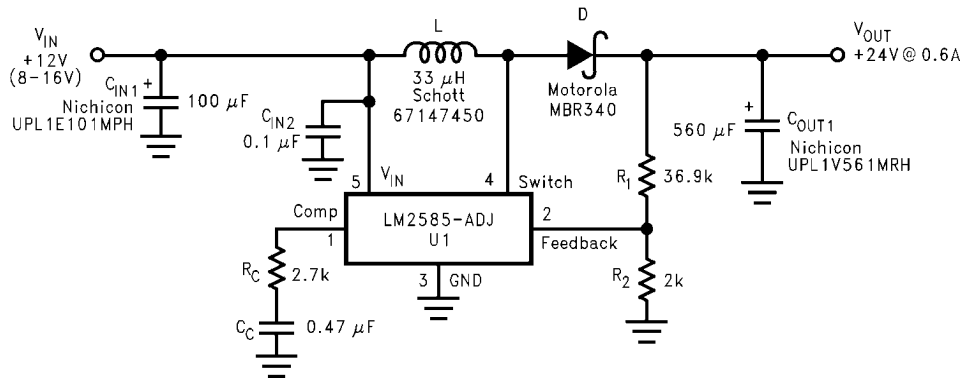

1251552

FIGURE 35. +12V to +24V Boost Regulator

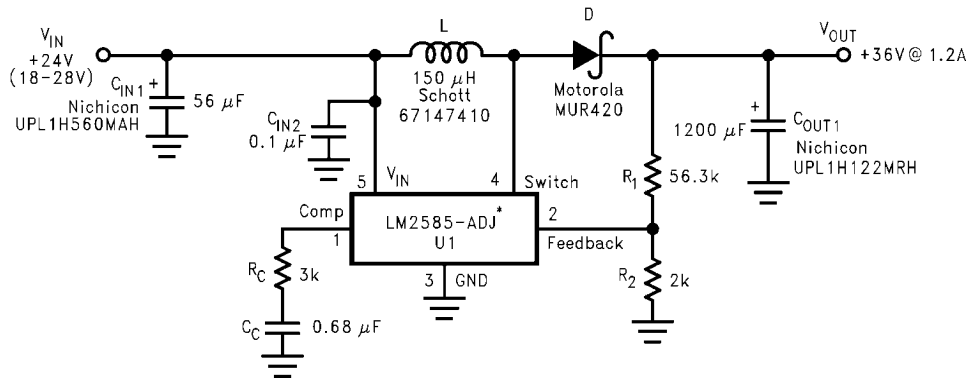

1251553

FIGURE 36. +24V to +36V Boost Regulator

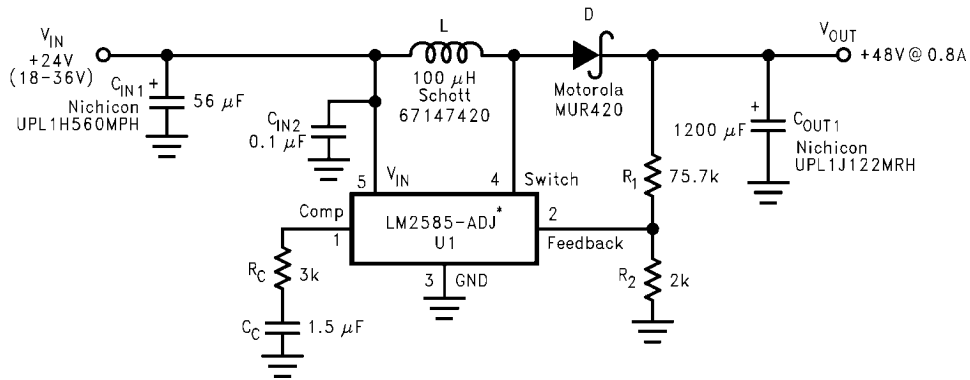

1251554

\*The LM2585 will require a heat sink in these applications. The size of the heat sink will depend on the maximum ambient temperature. To calculate the thermal resistance of the IC and the size of the heat sink needed, see the "Heat Sink/Thermal Considerations" section in the Application Hints.

FIGURE 37. +24V to +48V Boost Regulator

## Application Hints

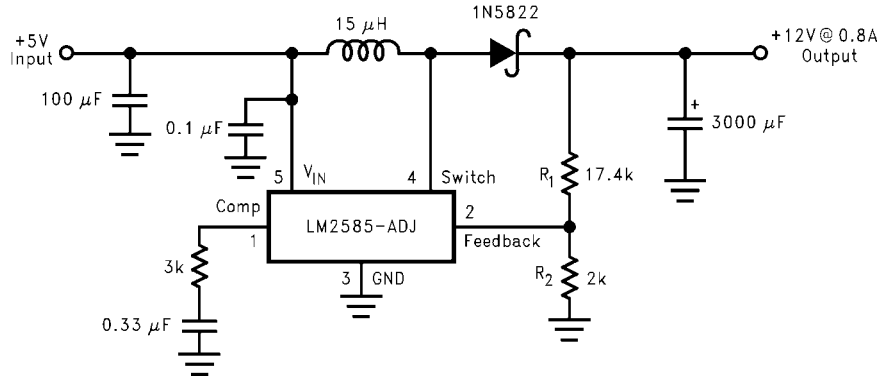

1251555

FIGURE 38. Boost Regulator

### PROGRAMMING OUTPUT VOLTAGE (SELECTING $R_1$ AND $R_2$ )

Referring to the adjustable regulator in *Figure 38*, the output voltage is programmed by the resistors  $R_1$  and  $R_2$  by the following formula:

$$V_{OUT} = V_{REF} (1 + R_1/R_2) \quad \text{where } V_{REF} = 1.23V$$

Resistors  $R_1$  and  $R_2$  divide the output voltage down so that it can be compared with the 1.23V internal reference. With  $R_2$  between 1k and 5k,  $R_1$  is:

$$R_1 = R_2 (V_{OUT}/V_{REF} - 1) \quad \text{where } V_{REF} = 1.23V$$

For best temperature coefficient and stability with time, use 1% metal film resistors.

### SHORT CIRCUIT CONDITION

Due to the inherent nature of boost regulators, when the output is shorted (see *Figure 38*), current flows directly from the

input, through the inductor and the diode, to the output, bypassing the switch. The current limit of the switch *does not* limit the output current for the entire circuit. To protect the load and prevent damage to the switch, the current must be externally limited, either by the input supply or at the output with an external current limit circuit. The external limit should be set to the maximum switch current of the device, which is 3A.

In a flyback regulator application (*Figure 39*), using the standard transformers, the LM2585 will survive a short circuit to the main output. When the output voltage drops to 80% of its nominal value, the frequency will drop to 25 kHz. With a lower frequency, off times are larger. With the longer off times, the transformer can release all of its stored energy before the switch turns back on. Hence, the switch turns on initially with zero current at its collector. In this condition, the switch current limit will limit the peak current, saving the device.

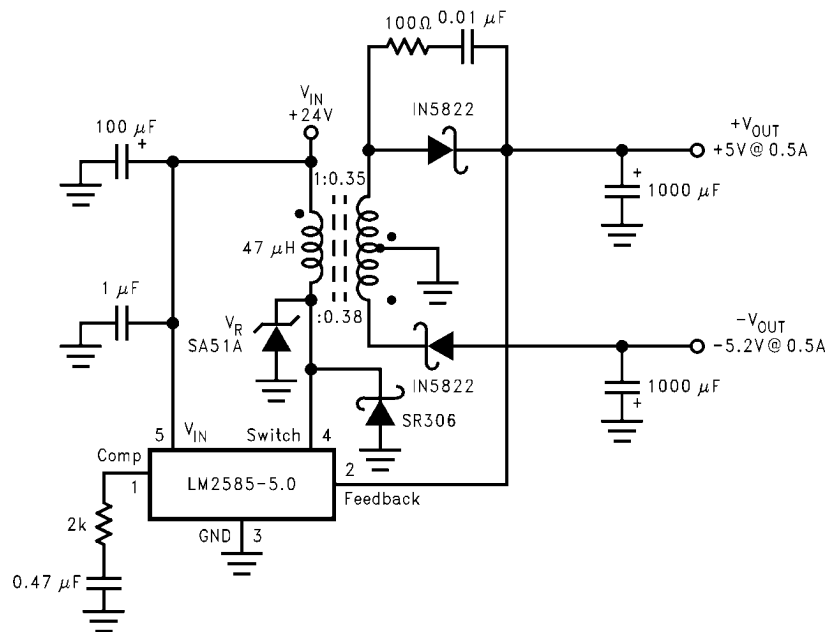

1251556

FIGURE 39. Flyback Regulator

## FLYBACK REGULATOR INPUT CAPACITORS

A flyback regulator draws discontinuous pulses of current from the input supply. Therefore, there are two input capacitors needed in a flyback regulator; one for energy storage and one for filtering (see *Figure 39*). Both are required due to the inherent operation of a flyback regulator. To keep a stable or constant voltage supply to the LM2585, a storage capacitor ( $\geq 100 \mu\text{F}$ ) is required. If the input source is a rectified DC supply and/or the application has a wide temperature range, the required rms current rating of the capacitor might be very large. This means a larger value of capacitance or a higher voltage rating will be needed of the input capacitor. The storage capacitor will also attenuate noise which may interfere with other circuits connected to the same input supply voltage. In addition, a small bypass capacitor is required due to the noise generated by the input current pulses. To eliminate the noise, insert a  $1.0 \mu\text{F}$  ceramic capacitor between  $V_{\text{IN}}$  and ground as close as possible to the device.

## SWITCH VOLTAGE LIMITS

In a flyback regulator, the maximum steady-state voltage appearing at the switch, when it is off, is set by the transformer turns ratio,  $N$ , the output voltage,  $V_{\text{OUT}}$ , and the maximum input voltage,  $V_{\text{IN}}(\text{Max})$ :

$$V_{\text{SW(OFF)}} = V_{\text{IN}}(\text{Max}) + (V_{\text{OUT}} + V_{\text{F}})/N$$

where  $V_{\text{F}}$  is the forward biased voltage of the output diode, and is  $0.5\text{V}$  for Schottky diodes and  $0.8\text{V}$  for ultra-fast recovery diodes (typically). In certain circuits, there exists a voltage spike,  $V_{\text{LL}}$ , superimposed on top of the steady-state voltage (see *Figure 5*, waveform A). Usually, this voltage spike is caused by the transformer leakage inductance and/or the output rectifier recovery time. To “clamp” the voltage at the switch from exceeding its maximum value, a transient suppressor in series with a diode is inserted across the transformer primary (as shown in the circuit on the front page and other flyback regulator circuits throughout the datasheet). The schematic in *Figure 39* shows another method of clamping the switch voltage. A single voltage transient suppressor (the SA51A) is inserted at the switch pin. This method clamps the total voltage across the switch, not just the voltage across the primary.

If poor circuit layout techniques are used (see the “Circuit Layout Guideline” section), negative voltage transients may appear on the Switch pin (pin 4). Applying a negative voltage (with respect to the IC’s ground) to any monolithic IC pin causes erratic and unpredictable operation of that IC. This holds true for the LM2585 IC as well. When used in a flyback regulator, the voltage at the Switch pin (pin 4) can go negative when the switch turns on. The “ringing” voltage at the switch pin is caused by the output diode capacitance and the transformer leakage inductance forming a resonant circuit at the secondary(ies). The resonant circuit generates the “ringing” voltage, which gets reflected back through the transformer to the switch pin. There are two common methods to avoid this problem. One is to add an RC snubber around the output rectifier(s), as in *Figure 39*. The values of the resistor and the capacitor must be chosen so that the voltage at the Switch pin does not drop below  $-0.4\text{V}$ . The resistor may range in value between  $10\Omega$  and  $1 \text{ k}\Omega$ , and the capacitor will vary from  $0.001 \mu\text{F}$  to  $0.1 \mu\text{F}$ . Adding a snubber will (slightly) reduce the efficiency of the overall circuit.

The other method to reduce or eliminate the “ringing” is to insert a Schottky diode clamp between pins 4 and 3 (ground), also shown in *Figure 39*. This prevents the voltage at pin 4 from dropping below  $-0.4\text{V}$ . The reverse voltage rating of the diode must be greater than the switch off voltage.

## OUTPUT VOLTAGE LIMITATIONS

The maximum output voltage of a boost regulator is the maximum switch voltage minus a diode drop. In a flyback regulator, the maximum output voltage is determined by the turns ratio,  $N$ , and the duty cycle,  $D$ , by the equation:

$$V_{\text{OUT}} = N \times V_{\text{IN}} \times D / (1 - D)$$

The duty cycle of a flyback regulator is determined by the following equation:

$$D = \frac{V_{\text{OUT}} + V_{\text{F}}}{N(V_{\text{IN}} - V_{\text{SAT}}) + V_{\text{OUT}} + V_{\text{F}}} \approx \frac{V_{\text{OUT}}}{N(V_{\text{IN}}) + V_{\text{OUT}}}$$

Theoretically, the maximum output voltage can be as large as desired—just keep increasing the turns ratio of the transformer. However, there exists some physical limitations that prevent the turns ratio, and thus the output voltage, from increasing to infinity. The physical limitations are capacitances and inductances in the LM2585 switch, the output diode(s), and the transformer—such as reverse recovery time of the output diode (mentioned above).

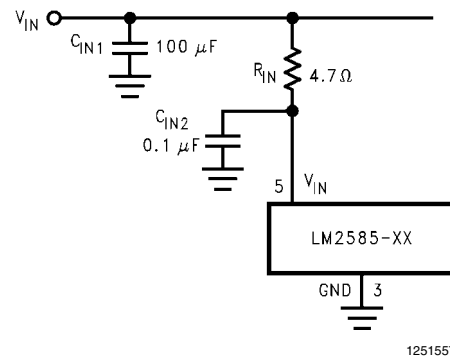

FIGURE 40. Input Line Filter

## NOISY INPUT LINE CONDITION

A small, low-pass RC filter should be used at the input pin of the LM2585 if the input voltage has an unusual large amount of transient noise, such as with an input switch that bounces. The circuit in *Figure 40* demonstrates the layout of the filter, with the capacitor placed from the input pin to ground and the resistor placed between the input supply and the input pin. Note that the values of  $R_{\text{IN}}$  and  $C_{\text{IN}}$  shown in the schematic are good enough for most applications, but some readjusting might be required for a particular application. If efficiency is a major concern, replace the resistor with a small inductor (say  $10 \mu\text{H}$  and rated at  $100 \text{ mA}$ ).

## STABILITY

All current-mode controlled regulators can suffer from an instability, known as subharmonic oscillation, if they operate with a duty cycle above 50%. To eliminate subharmonic oscillations, a minimum value of inductance is required to ensure stability for all boost and flyback regulators. The minimum inductance is given by:

$$L(\text{Min}) = \frac{2.92 [(V_{\text{IN}}(\text{Min}) - V_{\text{SAT}}) \times (2D(\text{Max}) - 1)]}{1 - D(\text{Max})} (\mu\text{H})$$

where  $V_{\text{SAT}}$  is the switch saturation voltage and can be found in the Characteristic Curves.

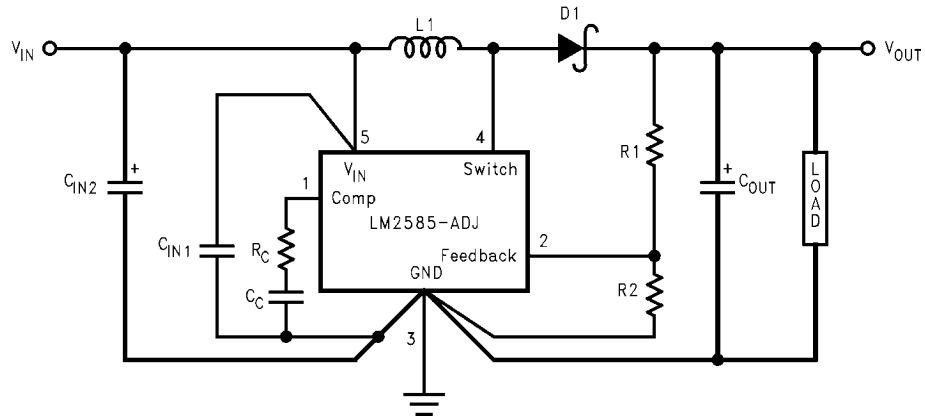

1251558

FIGURE 41. Circuit Board Layout

### CIRCUIT LAYOUT GUIDELINES

As in any switching regulator, layout is very important. Rapidly switching currents associated with wiring inductance generate voltage transients which can cause problems. For minimal inductance and ground loops, keep the length of the leads and traces as short as possible. Use single point grounding or ground plane construction for best results. Separate the signal grounds from the power grounds (as indicated in Figure 41). When using the Adjustable version, physically locate the programming resistors as near the regulator IC as possible, to keep the sensitive feedback wiring short.

### HEAT SINK/THERMAL CONSIDERATIONS

In many cases, no heat sink is required to keep the LM2585 junction temperature within the allowed operating range. For each application, to determine whether or not a heat sink will be required, the following must be identified:

- 1) Maximum ambient temperature (in the application).
- 2) Maximum regulator power dissipation (in the application).
- 3) Maximum allowed junction temperature (125°C for the LM2585). For a safe, conservative design, a temperature approximately 15°C cooler than the maximum junction temperature should be selected (110°C).
- 4) LM2585 package thermal resistances  $\theta_{JA}$  and  $\theta_{JC}$  (given in the Electrical Characteristics).

Total power dissipated ( $P_D$ ) by the LM2585 can be estimated as follows:

Boost:

$$P_D = 0.15\Omega \times \left( \frac{I_{LOAD}}{1-D} \right)^2 \times D + \frac{I_{LOAD}}{50 \times (1-D)} \times D \times V_{IN}$$

Flyback:

$$P_D = 0.15\Omega \times \left( \frac{N \times \Sigma I_{LOAD}}{1-D} \right)^2 \times D + \frac{N \times \Sigma I_{LOAD}}{50 \times (1-D)} \times D \times V_{IN}$$

$V_{IN}$  is the minimum input voltage,  $V_{OUT}$  is the output voltage,  $N$  is the transformer turns ratio,  $D$  is the duty cycle, and  $I_{LOAD}$  is the maximum load current (and  $\Sigma I_{LOAD}$  is the sum of the maximum load currents for multiple-output flyback regulators). The duty cycle is given by:

Boost:

$$D = \frac{V_{OUT} + V_F - V_{IN}}{V_{OUT} + V_F - V_{SAT}} \approx \frac{V_{OUT} - V_{IN}}{V_{OUT}}$$

Flyback:

$$D = \frac{V_{OUT} + V_F}{N(V_{IN} - V_{SAT}) + V_{OUT} + V_F} \approx \frac{V_{OUT}}{N(V_{IN}) + V_{OUT}}$$

where  $V_F$  is the forward biased voltage of the diode and is typically 0.5V for Schottky diodes and 0.8V for fast recovery diodes.  $V_{SAT}$  is the switch saturation voltage and can be found in the Characteristic Curves.

When no heat sink is used, the junction temperature rise is:

$$\Delta T_J = P_D \times \theta_{JA}$$

Adding the junction temperature rise to the maximum ambient temperature gives the actual operating junction temperature:

$$T_J = \Delta T_J + T_A$$

If the operating junction temperature exceeds the maximum junction temperature in item 3 above, then a heat sink is required. When using a heat sink, the junction temperature rise can be determined by the following:

$$\Delta T_J = P_D \times (\theta_{JC} + \theta_{Interface} + \theta_{Heat\ Sink})$$

Again, the operating junction temperature will be:

$$T_J = \Delta T_J + T_A$$

As before, if the maximum junction temperature is exceeded, a larger heat sink is required (one that has a lower thermal resistance).

Included in the **Switchers Made Simple** design software is a more precise (non-linear) thermal model that can be used to determine junction temperature with different input-output parameters or different component values. It can also calculate the heat sink thermal resistance required to maintain the regulator junction temperature below the maximum operating temperature.

To further simplify the flyback regulator design procedure, National Semiconductor is making available computer design software to be used with the Simple Switcher line of switching regulators. **Switchers Made Simple** is available on a 3½ diskette for IBM compatible computers from a National Semiconductor sales office in your area or the National Semiconductor Customer Response Center (1-800-272-9959).



## **European Magnetic Vendor**

### **Contacts**

Please contact the following addresses for details of local distributors or representatives:

#### **Coilcraft**

21 Napier Place  
Wardpark North  
Cumbernauld, Scotland G68 0LL

Phone: +44 1236 730 595

Fax: +44 1236 730 627

#### **Pulse Engineering**

Dunmore Road

Tuam

Co. Galway, Ireland

Phone: +353 93 24 107

Fax: +353 93 24 459

**Physical Dimensions** inches (millimeters) unless otherwise noted

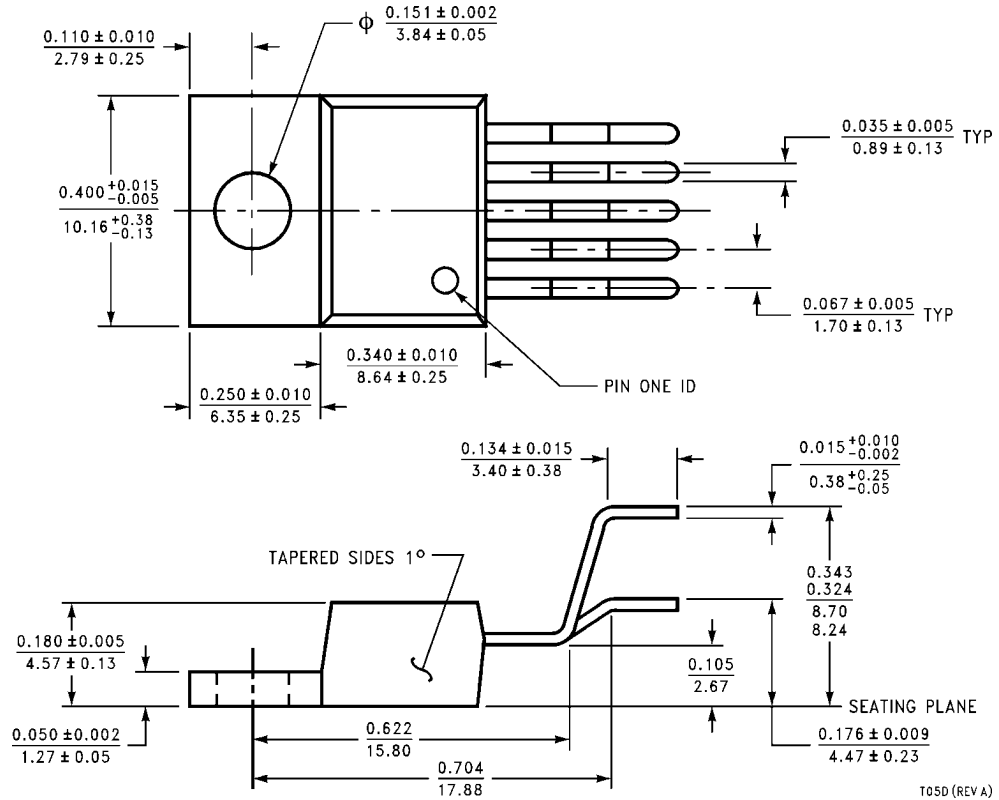

**Order Number LM2585T-3.3, LM2585T-5.0,  
LM2585T-12 or LM2585T-ADJ  
NS Package Number T05D**

T05D (REV A)

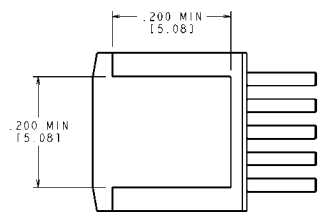
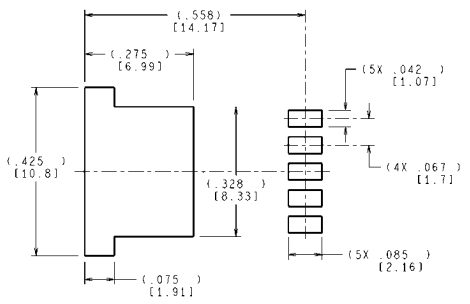
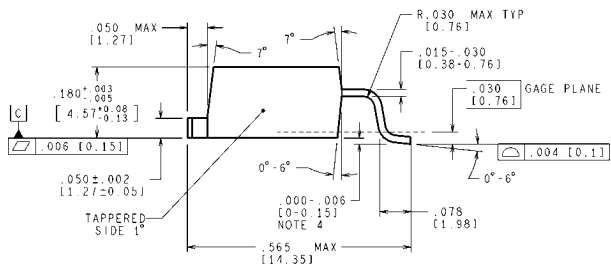
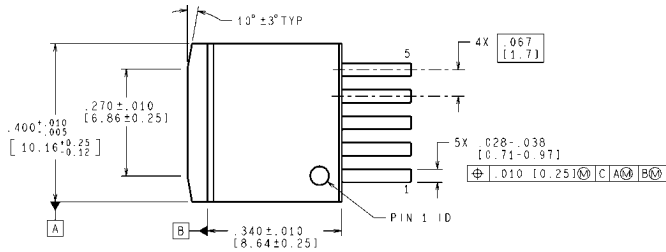

CONTROLLING DIMENSION IS INCH  
 VALUES IN [ ] ARE MILLIMETERS  
 DIMENSIONS IN ( ) FOR REFERENCE ONLY

**Order Number LM2585S-3.3, LM2585S-5.0,  
 LM2585S-12 or LM2585S-ADJ  
 NS Package Number TS5B**

TS5B (Rev D)

## Notes

THE CONTENTS OF THIS DOCUMENT ARE PROVIDED IN CONNECTION WITH NATIONAL SEMICONDUCTOR CORPORATION ("NATIONAL") PRODUCTS. NATIONAL MAKES NO REPRESENTATIONS OR WARRANTIES WITH RESPECT TO THE ACCURACY OR COMPLETENESS OF THE CONTENTS OF THIS PUBLICATION AND RESERVES THE RIGHT TO MAKE CHANGES TO SPECIFICATIONS AND PRODUCT DESCRIPTIONS AT ANY TIME WITHOUT NOTICE. NO LICENSE, WHETHER EXPRESS, IMPLIED, ARISING BY ESTOPPEL OR OTHERWISE, TO ANY INTELLECTUAL PROPERTY RIGHTS IS GRANTED BY THIS DOCUMENT.

TESTING AND OTHER QUALITY CONTROLS ARE USED TO THE EXTENT NATIONAL DEEMS NECESSARY TO SUPPORT NATIONAL'S PRODUCT WARRANTY. EXCEPT WHERE MANDATED BY GOVERNMENT REQUIREMENTS, TESTING OF ALL PARAMETERS OF EACH PRODUCT IS NOT NECESSARILY PERFORMED. NATIONAL ASSUMES NO LIABILITY FOR APPLICATIONS ASSISTANCE OR BUYER PRODUCT DESIGN. BUYERS ARE RESPONSIBLE FOR THEIR PRODUCTS AND APPLICATIONS USING NATIONAL COMPONENTS. PRIOR TO USING OR DISTRIBUTING ANY PRODUCTS THAT INCLUDE NATIONAL COMPONENTS, BUYERS SHOULD PROVIDE ADEQUATE DESIGN, TESTING AND OPERATING SAFEGUARDS.

EXCEPT AS PROVIDED IN NATIONAL'S TERMS AND CONDITIONS OF SALE FOR SUCH PRODUCTS, NATIONAL ASSUMES NO LIABILITY WHATSOEVER, AND NATIONAL DISCLAIMS ANY EXPRESS OR IMPLIED WARRANTY RELATING TO THE SALE AND/OR USE OF NATIONAL PRODUCTS INCLUDING LIABILITY OR WARRANTIES RELATING TO FITNESS FOR A PARTICULAR PURPOSE, MERCHANTABILITY, OR INFRINGEMENT OF ANY PATENT, COPYRIGHT OR OTHER INTELLECTUAL PROPERTY RIGHT.

### LIFE SUPPORT POLICY

**NATIONAL'S PRODUCTS ARE NOT AUTHORIZED FOR USE AS CRITICAL COMPONENTS IN LIFE SUPPORT DEVICES OR SYSTEMS WITHOUT THE EXPRESS PRIOR WRITTEN APPROVAL OF THE CHIEF EXECUTIVE OFFICER AND GENERAL COUNSEL OF NATIONAL SEMICONDUCTOR CORPORATION.** As used herein:

Life support devices or systems are devices which (a) are intended for surgical implant into the body, or (b) support or sustain life and whose failure to perform when properly used in accordance with instructions for use provided in the labeling can be reasonably expected to result in a significant injury to the user. A critical component is any component in a life support device or system whose failure to perform can be reasonably expected to cause the failure of the life support device or system or to affect its safety or effectiveness.

National Semiconductor and the National Semiconductor logo are registered trademarks of National Semiconductor Corporation. All other brand or product names may be trademarks or registered trademarks of their respective holders.

Copyright© 2007 National Semiconductor Corporation

For the most current product information visit us at [www.national.com](http://www.national.com)



**National Semiconductor  
Americas Customer  
Support Center**  
Email:  
[new.feedback@nsc.com](mailto:new.feedback@nsc.com)  
Tel: 1-800-272-9959

**National Semiconductor Europe  
Customer Support Center**  
Fax: +49 (0) 180-530-85-86  
Email: [europe.support@nsc.com](mailto:europe.support@nsc.com)  
Deutsch Tel: +49 (0) 69 9508 6208  
English Tel: +49 (0) 870 24 0 2171  
Français Tel: +33 (0) 1 41 91 8790

**National Semiconductor Asia  
Pacific Customer Support Center**  
Email: [ap.support@nsc.com](mailto:ap.support@nsc.com)

**National Semiconductor Japan  
Customer Support Center**  
Fax: 81-3-5639-7507  
Email: [jpn.feedback@nsc.com](mailto:jpn.feedback@nsc.com)  
Tel: 81-3-5639-7560